

LDT

COSTRUZIONE MATERIALE ELETTRICO PALI PER ILLUMINAZIONE PUBBLICA



Certificato di conformità CE
1608 CPD P033

Revisione n°:	Proposto da :	Approvato da :	DATA :
01			01-01-07

LDT

TIPS FOR THE INSTALLATION OF A POLYGONAL POLE

PREMISE

The installation of polygonal poles in two sections by grafting involves mechanical measures aimed to the success of the same and the relative lifting of the product question.

It 'very important to entrust the installation to specialized companies and equipped with all the necessary equipment for the assembly of poles polygonal coupling.

A thorough read and follow the instructions given in this manual, encourage the mount and laying, and also ensure a perfect functionality 'of the product installed.

PREMISE THAT IS MADE OTHERWISE THE FULL AND ECLUSIVITY RESPONSIBILITY OF THE 'ENTERPRISE SPECIALIZED AND IN CHARGE OF ASSEMBLY: report of diagrams and helpful hints for the installation of product supplied.

Ufficio Tecnico

(ing. Luca Messini)

LDT

INSTALLATION MANUAL

The company responsible for the installation of the property must comply with the following during the installation phase.

The polygonal pole in two sections **MUST BE** necessarily coupled with the following the methodology of work:

1 - Alignment of the logs according to the specification of the pole (two or more 'logs'), above the wooden sleepers and in the vicinity 'of the foundation.

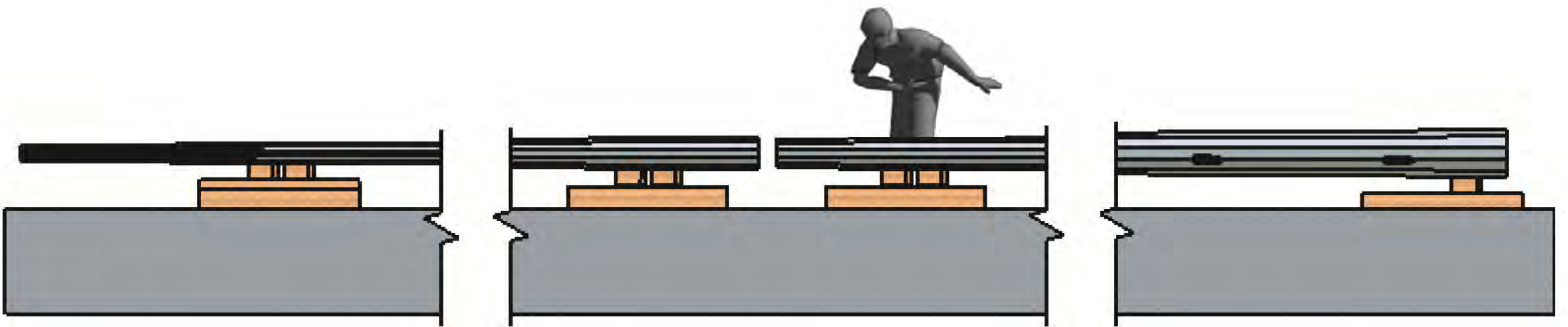

Fig.1

2 - Clean the contact surfaces to remove foreign bodies, harshness' and other any imperfections which may affect the pair of trunks.

3 - Marking of the signs of graft on the extreme part of the trunk of the base as indicated by the project (360 min / 500 max)

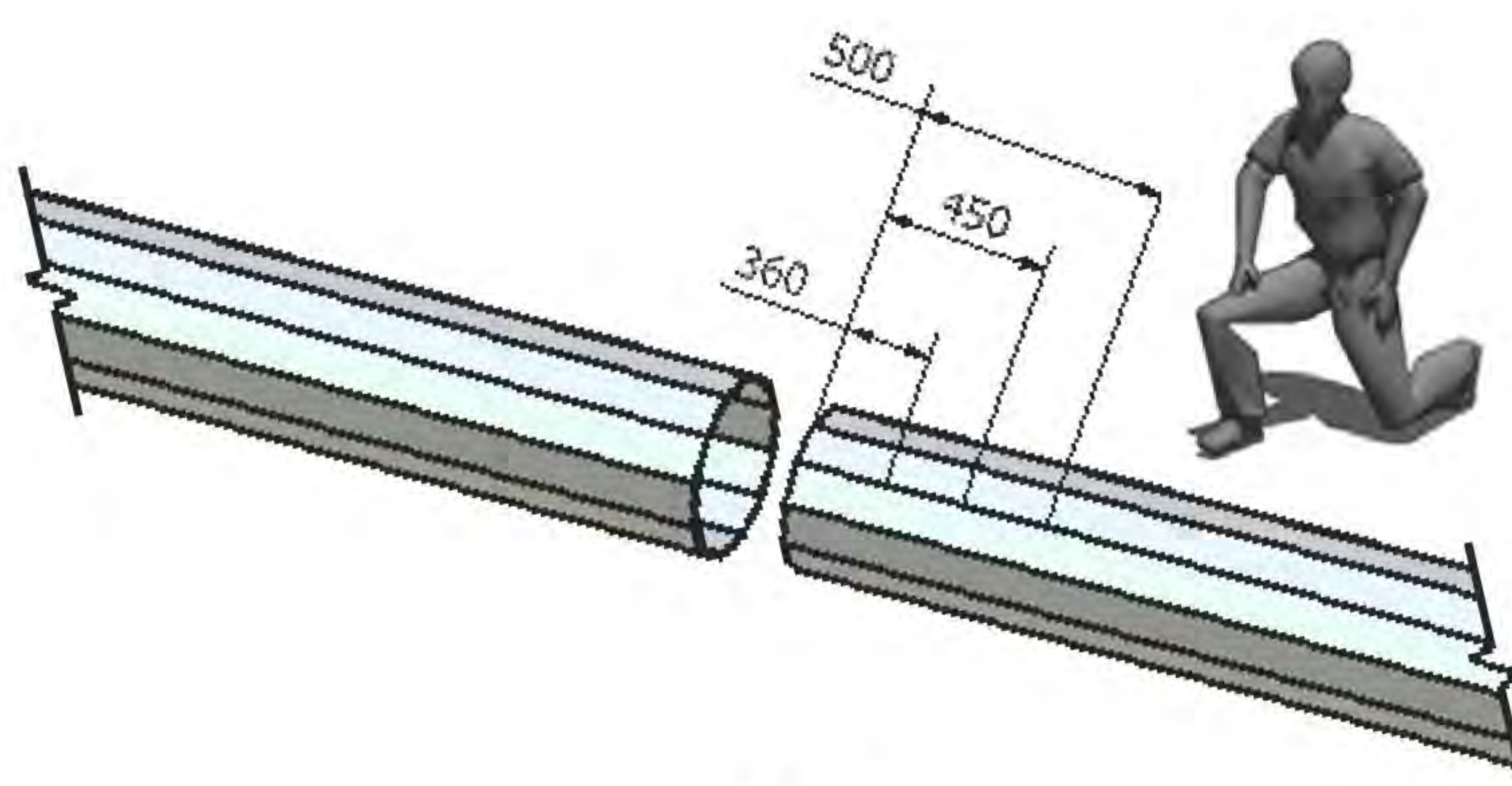

Fig.2

4 - Application of one or two TIRFORTS overall power higher than the maximum force of graft indicated in the project (2500 kgf).

5 - Apply the parts in contact with each other during mating (at least 200 mm approximately) of the spray silicone-based in order to facilitate the sliding.

6 - Running to the ground via Graft tirtots, gradually increasing the intensity 'up to that the overlap does not change more' under the effect of the applied forces.

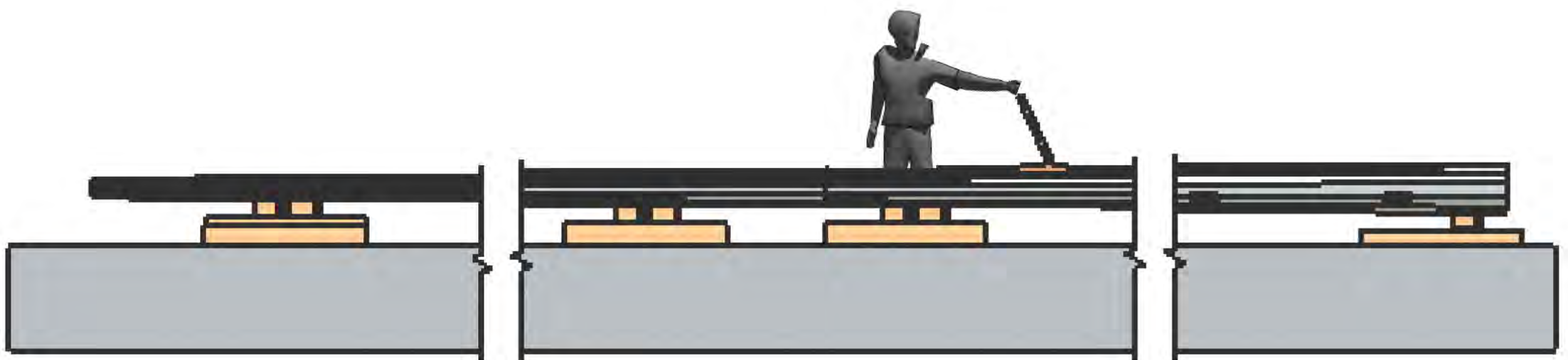

Fig.3

During the application of the clamping force with tirtots, in correspondence of the coupling part of the run small percussion through a body disk (example the hammer) taking care to interpose an object that avoids dents.

7 - LIFTING must be done by sling to "strangle" the ASSEMBLED TOWER, by a cable that conforms to the relevant standards security.
To ensure the necessary verticality 'sling must be placed at $H = 10,000$ mm between the base of the tower and the harness.



Fig.4

8 - Lifting of the tower by crane to the ground, and to detachment threading in the base of the foundation by matching the workings of according to the existing electrical outlets.

9 - Sealing of the tower by No. 2 plumb installed on special supports, in two points of observation at 90° between them.

The center of the base and the top 'must match the thread, while each any imperfection of linearity 'intermediate should be ignored for the purposes the seal (in testing at the factory tolerances are allowed to linearity ' manufacturing and galvanizing in accordance with EN 40-2).